



# INSTALLATION AND USER'S MANUAL

Language	USA English
Product	<b>Z-SUPPLY</b>
Description	<b>Single-phase switching power supply: 24 VDC @ 1.5A</b>

<b>Contents:</b>	<b>Page</b>
1.0 Disclaimer	2
2.0 Description and General features	2
2.1 Description	
2.2 General features	
3.0 Technical specifications	2
3.1 General specifications	
3.2 Power supply / input	
3.3 Output voltage	
3.4 Output relay, «power good»	
3.5 Enclosure	
3.6 Connectors	
3.7 Environmental conditions	
3.8 Standards	
3.9 Module layout	
4.0 Preparation and precautions	4
5.0 Installation	5
5.1 Installation / removal from DIN 46277 rail	
6.0 Electrical connections	6
6.1 Power supply	
6.2 24 VDC-output by screw terminal	
6.3 24 VDC-output by IDC10 for Seneca modules	
6.4 Output relay and «power-good»	
7.0 LEDs for signalling	7
8.0 Accessories	8



Manufacturer	 <p>UNI EN ISO 9001    CERTIFICATE Nr. 9115.SENE</p>	<p><b>Seneca s.r.l.</b> Via Austria, 26 35127 - PADOVA - ITALIA Tel. +39.049.8705355 - 8705359 - Fax +39.049.8706287</p>
Web		<a href="http://www.seneca.it">www.seneca.it</a>
Mail		<p>Technical support: <a href="mailto:support@seneca.it">support@seneca.it</a> Product information: <a href="mailto:sales@seneca.it">sales@seneca.it</a></p>

This document is property of SENECA srl. Duplication and reproduction are forbidden, if not authorized. Contents of the present documentation refers to products and technologies described in it. All technical data contained in the document may be modified without prior notice Content of this documentation is subject to periodical revision.

## 1.0 DISCLAIMER



Before executing any operation it's mandatory to read all the content of this user manual. Only electrical-skilled technicians can use the module described in this user Manual; it is responsibility of the installer to verify that the installation complies with safety standards.



Only the Manufacturer is authorized to repair the module or to replace damaged components.



No warranty is guaranteed in connection with faults resulting from improper use, from modifications or repairs carried out by Manufacturer-unauthorized personnel on the module, or if the content of this user Manual is not followed.



This module is designed for connection to hazardous electric voltages. Ignoring this warning can result in severe personal injury or mechanical damage.

## 2.0 DESCRIPTION AND GENERAL FEATURES

### 2.1 Description

Single-phase switching power supply for Seneca modules: it can be installed on DIN 46277 rail. Input voltage range: 100-260 VAC @ 47 - 63 Hz; output: 24 VDC @ 1.5 A.

### 2.2 General features

- AC input rated voltage from 110 VAC to 230 VAC @ 47-63 Hz, 0.7 A
- DC input rated voltage from 110 VDC to 315 VDC @ 0.7 A
- Output voltage: 24 VDC  $\pm$ 2% (two Z-SUPPLY units may be connected in parallel for output redundancy, ONLY by using the IDC10 connector)
- Output maximum-current: 1.5 A
- Internal fuse: 1.25 A, type T (delayed), for the protection against over-current and over-voltage
- Quick installation on DIN 46277 rail
- Isolation up to 3 kVAC between input voltage and output voltage
- LED to signal the status of the output voltage and power supply
- It is possible to supply the Seneca Z-PC Line modules through IDC10 connector

## 3.0 TECHNICAL SPECIFICATIONS

### 3.1 General specifications

Efficiency	87% @ 1.5 A, 230 V, $\cos\Phi$ 0.7
Power supplied	36 W max.
Isolation between: input, output	3 kVAC / 60 sec
Over-voltage category/Pollution degree	II/2
Power consumption (no load)	< 1.4 W
Power consumption (full load)	< 6.6 W
Current trip protection	1.7 A

Max resistive load	15 Ω
Max capacitive load	3000 μF
Output ripple	< 40 mV
Output regulation	< 1%
Dynamic regulation	< 1%
Turn-off time	15 ms @ 120 VAC, 60 ms @ 230 VAC

### 3.2 Power supply input

Rated voltage	110-240 V @ 50-60 Hz
Input range for AC power supply	100-265 V @ 47-63 Hz; 110-315 VDC
Current consumption	Max 0.7A @ 100V; 0.27 A @ 265 V
External input fuse (recommended)	2 A, type T
Internal input fuse	1.25 A, type T (delayed), it can not be replaced
Inrush current limitation (plug in)	<25 A
Power factor	>0.60
Start-up voltage with full load	~100 VAC (with load: 15 Ω)
Shut-down voltage	~90 VAC

### 3.3 Output voltage

Output voltage	24 VDC ±2 %
Output redundancy (Two Z-SUPPLY modules)	The output of a Z-SUPPLY can be parallel-connected with the output of another Z-SUPPLY( <b>only</b> by IDC10);see fig.6
Max output current	1.5 A
Over-load limit current	1.7 A
Load regulation	< 1%
Rated ripple	< 50 mVpp
Protection against short-circuit and over-load	Yes, hiccup @ over-load limit with auto reset

Derating curve for output, the derate starts at 55°C for 0.02 A/K

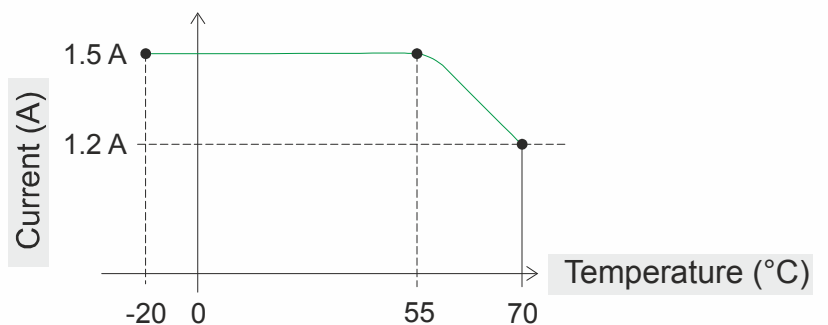

### 3.4 Output relay, «power-good»

Relay type	N.O. with 1 A / 30 VDC (resistive)
Relay activation	Output voltage > 23.5 VDC

### 3.5 Enclosure

Dimension	35 mm W x 100 mm H x 111 mm D
Box; protection class	Black plastic, IP20 (Ingress protection)
Weight	215 g

### 3.6 Connectors

Connectors	IDC with 10 pins for Seneca bus (output redundancy)
	Removable screw terminals: pitch 5.08 mm

### 3.7 Environmental conditions

Operating temperature	-20°C to +70°C
Humidity	30-90% RH at 40°C not condensing
Storage temperature	-40°C to +85°C

### 3.8 Standards

Standards	EN 61000-6-4/ 2007 (electromagnetic emission, in industrial environment)
	EN 61000-6-2/ 2005 (electromagnetic immunity, in industrial environment)
	EN 61010-1/ 2001 (safety)

### 3.9 Module layout

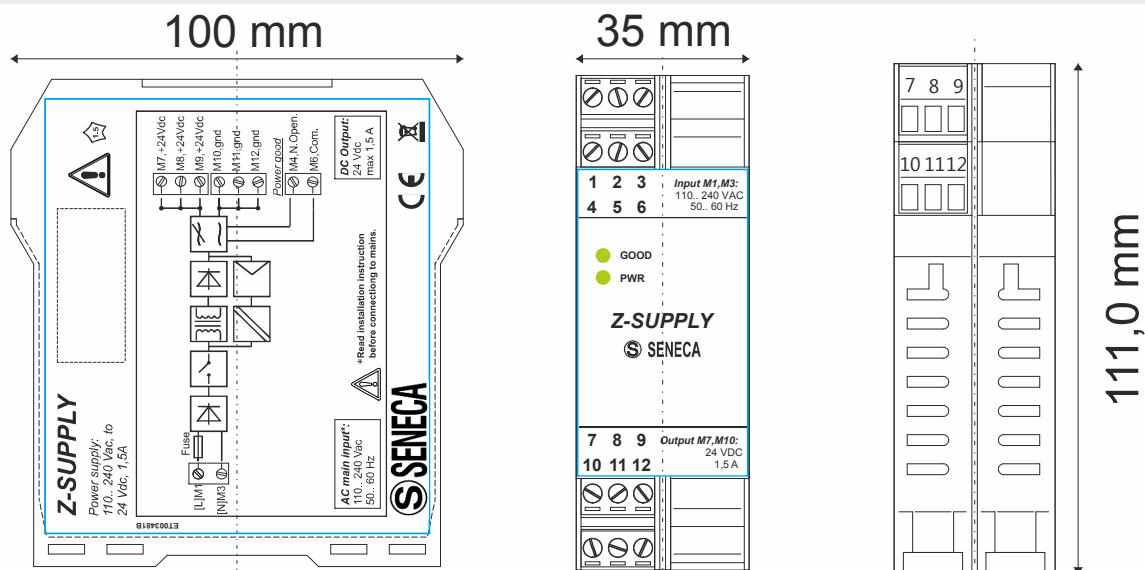

## 4.0 PREPARATION FOR INSTALLATION AND PRECAUTIONS

The module is must be installed in a vertical position on a horizontal DIN 46277 rail (fig. 1).



No installation or wiring of the module is allowed while it is powered on. **It is forbidden** to install the module near heat-emitting devices.



It is recommended that use and installation are performed by an electrically-skilled technician ensure safe wiring practices, and to avoid improper loads or connections.

The Z-SUPPLY module can achieve a very high temperature, so it is important to allow proper ventilation and be careful when using it.

## 5.0 INSTALLATION



Power off the module before cabling.

To install/remove the Z-SUPPLY on/from DIN 46277 rail, see Fig.1a and Fig.1b.

### 5.1 Installation on/removal from DIN 46277 rail

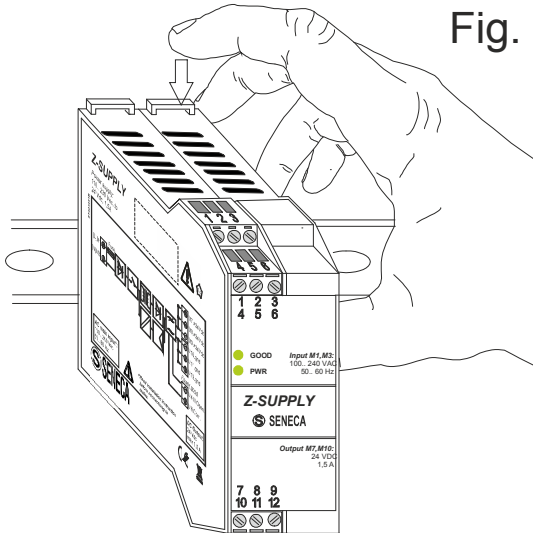

Fig. 1a

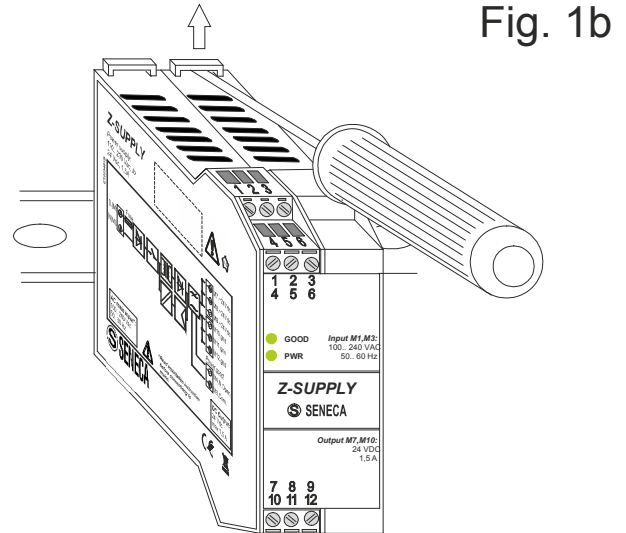

Fig. 1b

#### INSTALLATION

- 1) Pull the four latches (placed in the back-side panel) outwards.
- 2) Insert the module on the DIN rail.
- 3) Make sure that the IDC10-connector pins are inserted in the slot correctly.
- 4) Press the four latches inwards.

#### REMOVAL

- 1) Pull the four latches (placed in the back-side panel) outwards, using a screwdriver.
- 2) Pull the module out gently.

It's important to insert the pins in the slot correctly because IDC10-connectors are polarized. This connection is facilitated by use of a female/male insertion between IDC10 connector and DIN rail slot (Fig 1c and Fig 1d).

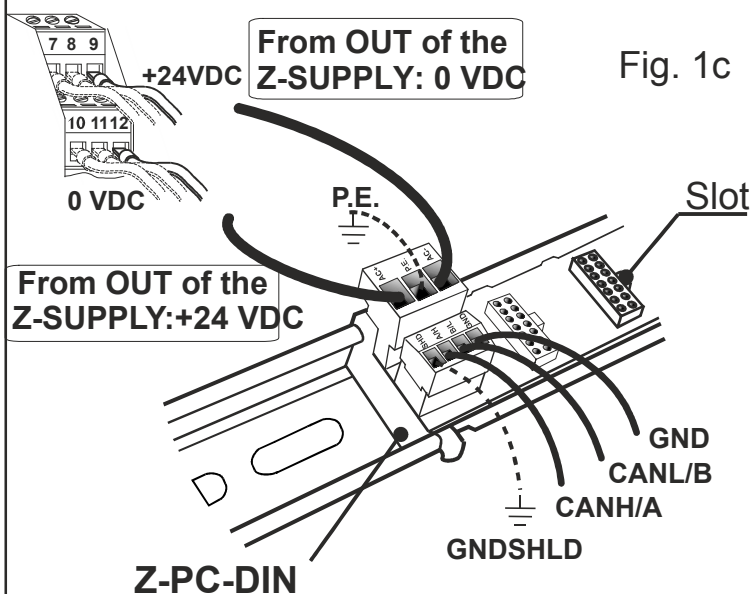

Fig. 1c

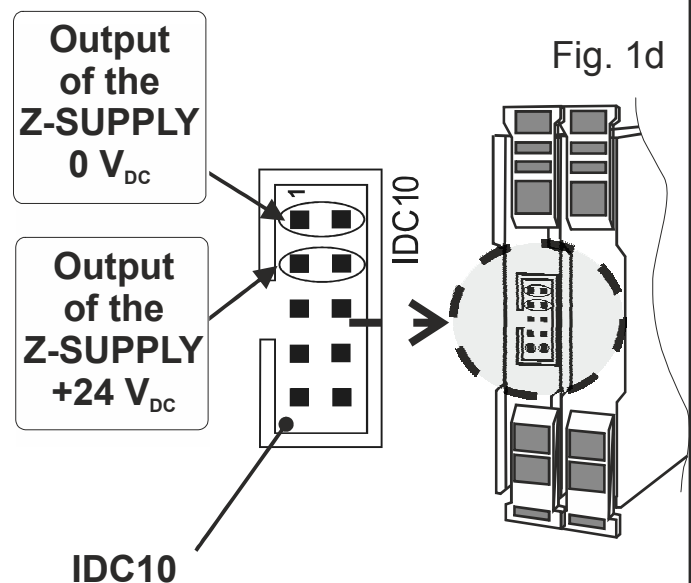

Fig. 1d

For better performance and long life, it is **forbidden** to obstruct the Z-SUPPLY ventilation openings (Fig. 2).

**ADEQUATE VENTILATION MUST BE PROVIDED!**

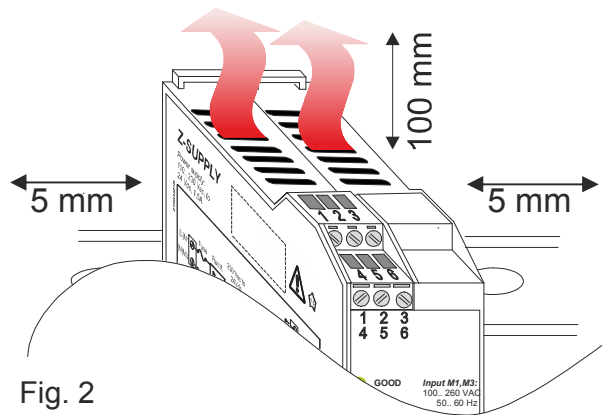

Fig. 2

## 6.0 ELECTRICAL CONNECTIONS

### 6.1 Power supply

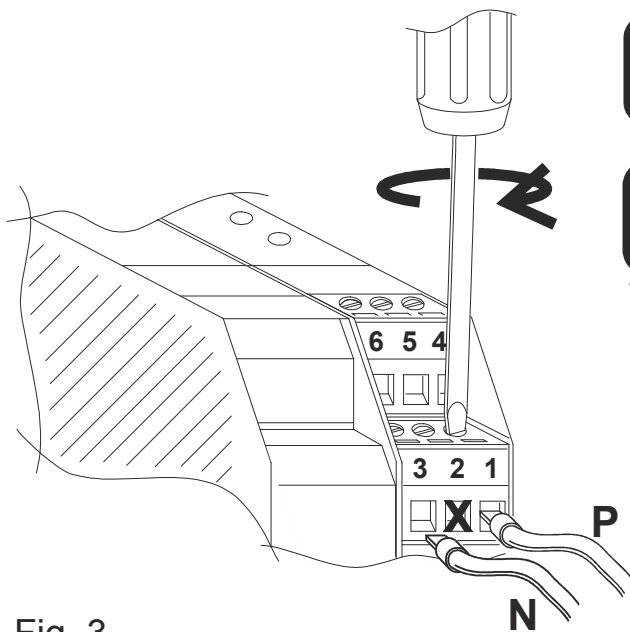

Fig. 3



The electrical connections should only be carried out when the module is disconnected and under ESD safe conditions.



**Make sure that the Z-SUPPLY power is off before wiring or installing.**

Before powering the Z-SUPPLY, it is necessary to correctly phase power (P) and neutral (N) of the single-phase network, at screw terminals 1 and 3.

#### Wire sizes



0.5 mm<sup>2</sup> to 2.5 mm<sup>2</sup> (20 AWG to 14 AWG)

### 6.2 24 VDC output screw terminals

The output is available on the screw terminals M7, M8, M9 (+24 VDC) and M10, M11, M12 (0 VDC) as shown in Fig.4.

The output is protected against current over-load. If the output is over-loaded, the Z-SUPPLY protection system will be activated automatically and output will not be stable (hiccup).

Protection status is shown through the «good» LED (blinking light). In this case, it is necessary to decrease the output load. When the Z-SUPPLY is restarted, it will be reset automatically.

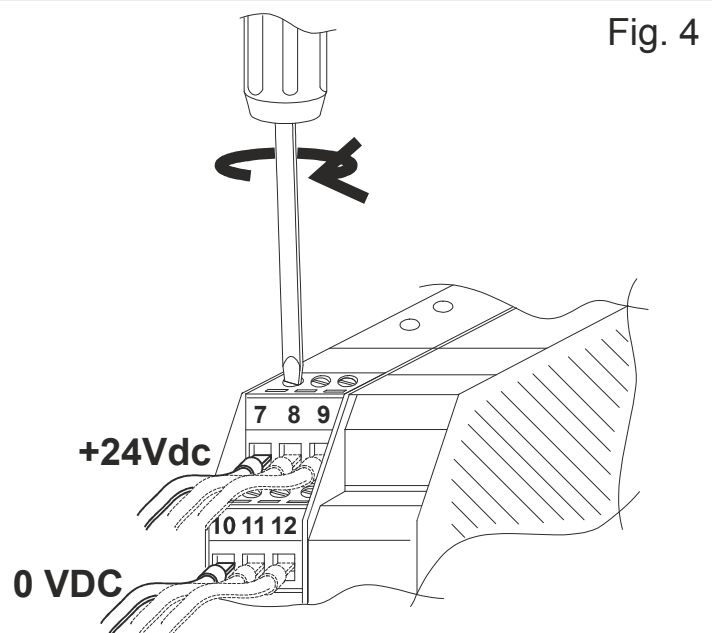

Fig. 4

## 6.3 24 VDC output with IDC10 for Seneca modules

Before using 24 VDC output through IDC10 connector, see Fig.1d and in Fig.1c. Through the IDC10 connector, the Z-SUPPLY can power up to 15 modules.

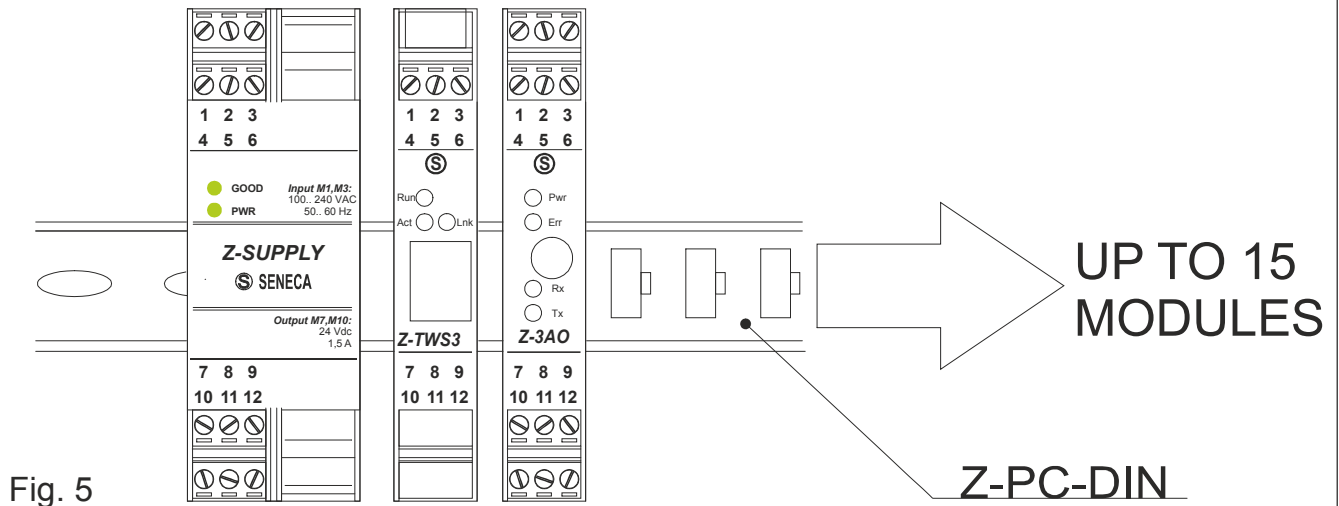

Fig. 5

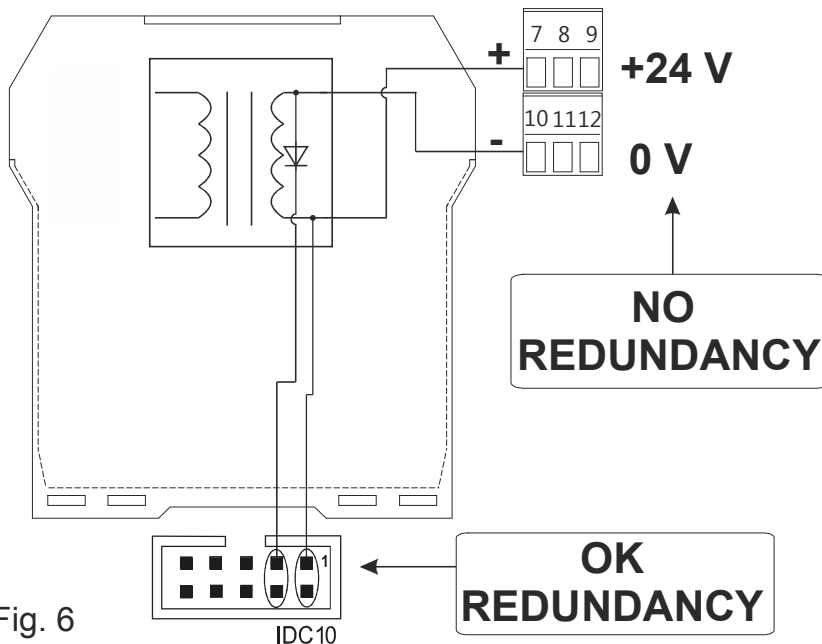



Fig. 6

 All connections shown in fig. 6 are internal, into the Z-SUPPLY.

As you can see in the fig. 6, there is a diode internally connected at the end of the IDC10 output, so it is possible to connect more Z-SUPPLY modules in parallel **ONLY** if the redundant outputs are connected by IDC10.

**IT IS FORBIDDEN** to connect more Z-SUPPLY modules in parallel using the redundant outputs by screw terminals (in alternative, connect a diode at the end of the output, for each Z-SUPPLY, externally).

## 6.4 Output relay and «power good»

The output voltage equal to 24 VDC is monitored by an internal relay, which enables the output voltage only if the voltage between its terminals is greater than 23.5 V. If the output voltage is supplied correctly, the LED «good» will be on; otherwise, if a over-loading occurs, the LED «good» will be blinking. The relay contact connections are at screw terminals M4 (normally open) and M6 (common).

## 7.0 LEDs for SIGNALLING

LED	STATUS	MEANING
Good	Constant light	24 VDC output is ON and regulated
	Off	24 VDC output is disabled
	Blinking light	Output over-load
Pwr	Constant light	24 VDC output is ON
	Off	24 VDC output is OFF

## 8.0 ACCESSORIES

CODE		DESCRIPTION
Z-PC-DIN	AL1-35	DIN rail support with screw terminals P=35 mm
	AL2-17.5	DIN rail support with screw terminals P=17.5 mm
Z-PC-DIN	1-35	DIN 1 slot support for rear connector P=35 mm
	2-17.5	DIN 2 slot support for rear connector P=17.5 mm
	4-35	DIN 4 slot support for rear connector P=35 mm
	8-17.5	DIN 8 slot support for rear connector P=17.5 mm



Disposal of Electrical & Electronic Equipment (Applicable throughout the European Union and other European countries with separate collections programs; see WEEE directive). This symbol, found on your product or on its packaging, indicates that this product should not be treated as household waste when you wish to dispose of it. Instead, it should be handed over to an applicable collection point for the recycling of electrical & electronic equipment. By ensuring this product is disposed of correctly, you will help prevent potential negative consequences to the environment and human health, which could otherwise be caused by inappropriate disposal of this product. The recycling of materials will help to conserve natural resources. For more detailed information about the recycling of the product, please contact your local city office, waste disposal service of the retail store where you purchased this product.