

Inputs: 4-20 mA, Two Channels
Outputs: 4-20 mA, Two Channels

- 2 Fully Independent Loop Powered Isolators
- 1000 Ω Output Drive Capability
- Calibration Unaffected by Change in Load
- Compact 22.5 mm Wide DIN Style Case
- Output LoopTracker® LED

Applications

- Isolate 4-20 mA Process Signals
- Isolate Two Loops With One API DPI-2
- Eliminate Ground Loops, Reduce Noise Effects

4-20 mA Inputs

Channel A: 4 to 20 mADC
 Channel B: 4 to 20 mADC

Input Voltage Burden

Approximately 9 VDC at 20 mA
 See graph on back

Maximum Input Voltage

60 VDC maximum

Common Mode Rejection

Negligible output effect for 50/60 Hz common mode signals

LoopTracker

Continuous visual indication of output loop current for each channel
 LED brightness varies with current level over 4-20 mA range

4-20 mA Outputs

Channel A: 4 to 20 mADC
 Channel B: 4 to 20 mADC

Output Drive Capability

Up to 1000 Ω with 20 V compliance at 20 mA at 30 VDC or approximately 750 Ω at 24 VDC depending on the supply voltage of the input loop.
 See graph on back.

Change in Load Effect

Less than ±0.08% of span for load changes from 0 Ω to 1000 Ω

Output Calibration

Multi-turn zero and span potentiometers for each output
 ±10% of span adjustment range typical

Accuracy

±0.1% of span (includes adjustment resolution and linearity)

Response Time

60 milliseconds typical

Isolation

1200 V_{RMS} minimum, input to output

Ambient Temperature Range and Stability

-10°C to +60°C operating ambient
 Better than ±0.2% of span per °C stability

Housing and Sockets

Polycarbonate housing
 Gray UL #94V-1 housing and black UL #94V-2 terminals
 IP 40, requires installation in panel or enclosure
 Mounts to 35 mm DIN rail

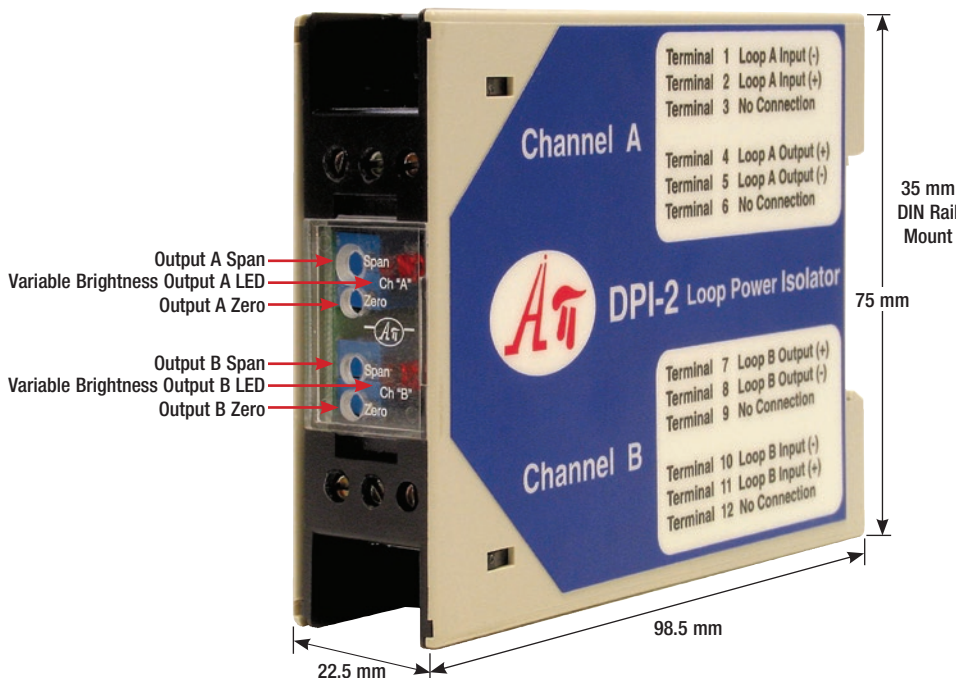

Description

The API DPI-2 is a two channel loop-powered isolator that accepts two separate 4-20 mADC inputs and provides two linear and isolated 4-20 mA outputs. The API DPI-2 contains two completely independent and identical channels in the same housing. When calculating power usage and reviewing specifications, consider each channel separately. The API DPI-2 derives its operating power from the input loop eliminating the need for external power supplies and additional power wiring.

Due to the unique design, the calibration and linearity of each channel is unaffected by output load changes from 0 to 1000 Ω. The API DPI-2 provides a cost effective, drop-in solution for eliminating the ground loops and noise problems commonly found in process loops.

LoopTracker

API exclusive features include a LoopTracker LED for each channel. The LoopTracker LED varies in intensity with changes in the process output signal. The LED will extinguish if either the input or output loops should open. Monitoring the state of these LEDs can provide a quick visual picture of your process loop and saves time during initial startup and/or troubleshooting.

Calibration

The API DPI-2 is factory calibrated and should not require re-calibration in the field for loads up to 1000 Ω. Each channel is totally independent from the other and each input is optically isolated from its corresponding output.

Should re-calibration (fine-tuning) be desired, independent Zero and Span controls for each channel are accessible through the front of the unit.

Installation

The API DPI-2 is designed to mount on an industry-standard DIN rail. The narrow 22.5 mm DIN style housing allows for side-by-side mounting of multiple modules for maximum I/O density with as many as 36 channels (18 modules) in a 19-inch rack.

Model	Input	Output	Power
API DPI-2	2 independent 4-20 mA channels	2 independent 4-20 mA channels	4-20 mA loop

Option—add to end of model number

U Conformal coating for moisture resistance

Electrical Connections

WARNING! Turn signal input, output, and power supplies off before connecting or disconnecting wiring.

This module mounts to an industry standard 35 mm DIN rail.

See wiring diagrams. All wiring must be performed by a qualified electrician or instrumentation engineer. Consult factory for assistance.

Signal Input Terminals

Polarity must be observed when connecting the signal input. If the input does not function, check wiring and polarity.

The DPI input sinks current. Your transmitter or an external loop power supply must provide power to each DPI input.

Signal Output Terminals

Polarity must be observed for output wiring connections. If the output does not function, check wiring and polarity.

Note that the module provides power to the output loop from the input loop.

API DPI-2 Loop A Input

Terminal 1 negative (-)
Terminal 2 positive (+)

API DPI-2 Loop A Output

Terminal 4 negative (-)
Terminal 5 positive (+)

API DPI-2 Loop B Input

Terminal 10 negative (-)
Terminal 11 positive (+)

API DPI-2 Loop B Output

Terminal 8 negative (-)
Terminal 7 positive (+)

Mounting

The housing clips to a standard 35 mm DIN rail. The housing is IP40 rated and should be mounted inside a panel or enclosure.

1. Tilt front of module downward and position the lower mount against the bottom edge of DIN rail.
2. Push front of module upward until upper mount snaps into place.

Removal

Avoid electrical hazards! Turn signal input, output, and power off.

1. Use a small flat-blade screwdriver to pry up on the black plastic spring clip located in the slot at top back of module.
2. Tilt front of module downward to release from the DIN rail.

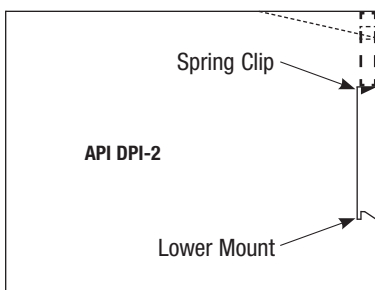

Input Voltage Burden Chart

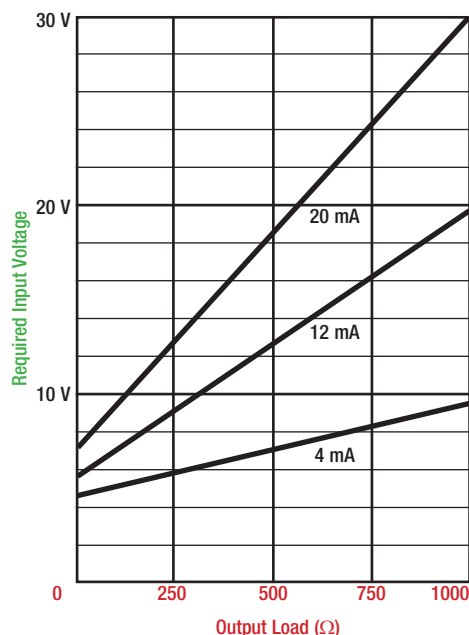

NOTE: The required input voltage is for one channel only.

Calibration

The API DPI-2 is factory calibrated and should not require recalibration in the field for loads of 0-1000 Ω.

Each channel is totally independent from the other and each input is isolated from its corresponding output.

Should recalibration (fine-tuning) be desired, independent Zero and Span controls for each channel are accessible through the front of the unit to adjust the module's output.

1. Wire unit as shown, apply power to the input and output loops, and allow a minimum 20 minute warm up time.
2. Using an accurate calibration source, provide a 4 mA input to module.
3. Using an accurate measurement device for the output, adjust the Zero potentiometer to 4 mA. The Zero control should only be adjusted when the input signal is at its minimum. This will produce a 4 mA output signal.
4. Using an accurate calibration source, provide 20 mA input to module.
5. Using an accurate measurement device for the output, adjust the Span potentiometer to 20 mA. The Span control should only be adjusted when the input signal is at its maximum. This will produce a 20 mA output signal.
6. Repeat adjustments for the second channel.

Operation

The API DPI-2 is a passive device that draws a small amount of power from the input loop to operate its isolation circuitry.

The red LoopTracker output LEDs provide a visual indication that the output signal is functioning. It becomes brighter as the input and the corresponding output change from minimum to maximum.

The red LED will only light if the output loop current path is complete. Failure to illuminate or a failure to change in intensity as the process changes may indicate a problem with the module input or output wiring. Note that it may be difficult to see the LED under bright lighting conditions.

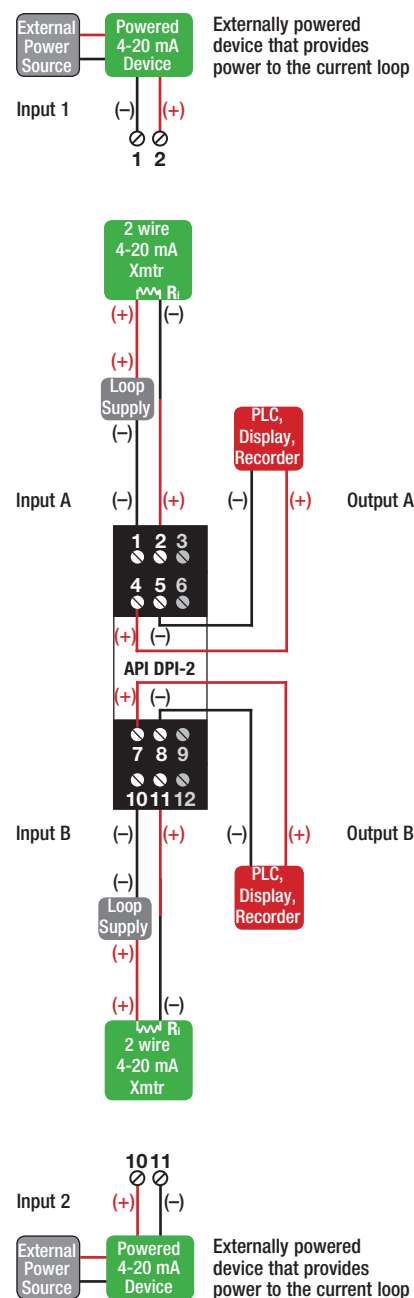

API maintains a constant effort to upgrade and improve its products. Specifications are subject to change without notice. Contact factory for assistance and see api-usa.com for latest datasheet version.